

# NFORCE NXT TOP COVER SERVICE PARTS

PNNLBTTXX(XY)

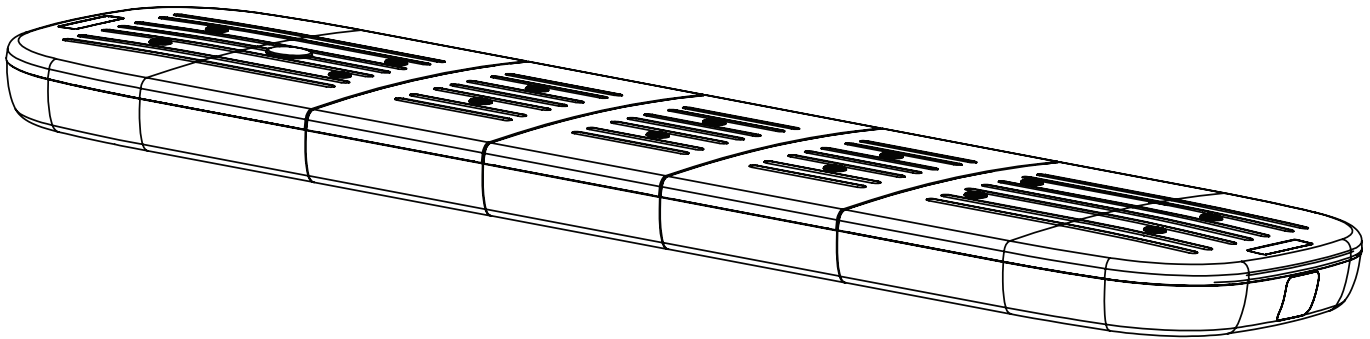

## WARNING

- HIGH CURRENT interconnects must be properly terminated. Poor crimp quality can cause heat build-up and fire. Follow crimp connector manufacturer instructions.
- DO NOT install this product or route any wires in the Air Bag Deployment Zone. Refer to vehicle Owner's Manual for deployment zones.
- Do NOT use system to disconnect headlights, brake lights or other safety equipment.
- Unit may become hot to touch during normal operation.
- Failure to properly install connectors, fuses or wiring may cause vehicle failure or fire.
- Installation must only be performed by trained technician. Installer must determine vehicle wiring configuration and proper integration of system.
- Use proper wire gauge. All power wires connecting to positive (+) or negative (-) battery terminal or local chassis ground (-) must be sized to supply at least 125% of max. current and properly fused at power source.
- Install protective grommets when routing wire through firewall or metal.

REQUIRED TOOLS LIST ..... 2

COMPONENTS ..... 2

INSTALLATION INSTRUCTIONS .... 2-3

 **WARNING**

ROUTE WIRES ONLY IN LOCATIONS THAT ARE NOT SUBJECTED TO POTENTIAL WEAR. MAKE SURE TO AVOID ROUTING WIRES IN THE DEPLOYMENT AREA OF YOUR AIR BAG. REFER TO YOUR VEHICLE'S OWNER'S MANUAL FOR AIRBAG DEPLOYMENT ZONES.



1.800.338.7337 / [www.soundoffsignal.com](http://www.soundoffsignal.com)

**NOTICE:**

Installers and users must comply with all applicable federal, state and local laws regarding use and installation of warning devices. *Improper use or installation may void warranty coverage. To review our Limited Warranty Statement & Return Policy for this or any SoundOff Signal product, visit our website at [www.soundoffsignal.com/tech-services/returns/](http://www.soundoffsignal.com/tech-services/returns/). If you have questions regarding this product, contact **Technical Services**, Monday - Friday, 8 a.m. to 5 p.m. ET at **1.800.338.7337** (press #4). Questions or comments that do not require immediate attention may be emailed to [techservices@soundoffsignal.com](mailto:techservices@soundoffsignal.com).*

ENHANCING SAFETY THROUGH INNOVATION

NFORCE NXT TOP COVER SERVICE PARTS  
0000KP 0125 REV B

**TOOLS REQUIRED:** //

- Flat head screwdriver
- T-15 Torx bit
- T-20 Torx bit
- Torque wrench (Inch-pounds)
- Foam tip brush (lubrication applicator)
- Allen wrench (For prying back snaps)

CONTAINS					
ITEM #	COMPONENT	PNNLBTTTE0(XY)	PNNLBTTTEA(XY)	PNNLBTTTLG(XY)	PNNLBTTTSM(XY)
		QTY			
1	NXT LB END TOP COVER W/O LENS	1	-	-	-
2	NXT LB END TOP COVER W/ LENS	-	1	-	-
3	NXT LB 12" TOP COVER LEXAN	-	-	1	-
4	NXT LB 6" TOP COVER LEXAN	-	-	-	1
5	#10 RBR WSHR .188 ID .438 OD .03THK	4	4	4	2
6	NUT - NF LB PLASTIC SQ #10 HOLE	4	4	4	2
7	SCREW - #10 X 2 PAN T20 THD FRM BLK	4	4	4	2
8	GSKT - NXT LB TOP COVER SEAL	4ft	4ft	4ft	3ft

**TOP COVER REPLACEMENT INSTRUCTIONS:** //

1. Use Torx T20 driver to remove all top cover screws.
  2. Remove old gaskets from screws (See FIG. 1).
  3. Remove gasket from lens rib on lens tubs (See FIG. 2). Repeat for all tubs.
  4. Remove adhesive backing residue that is left on the lens tub (See FIG. 3).
- NOTE: Do not use chemicals to remove the gasket residue.

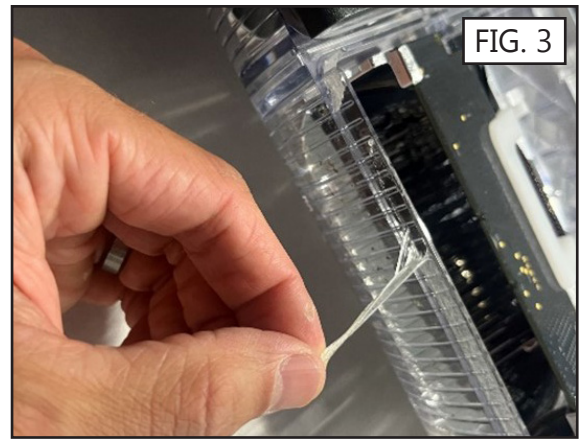
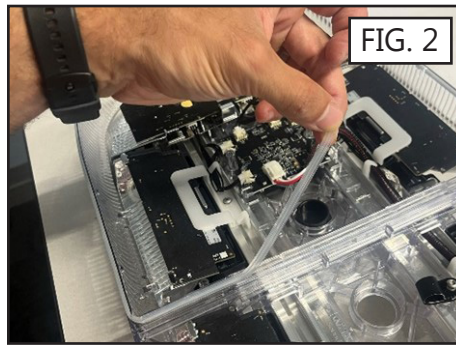
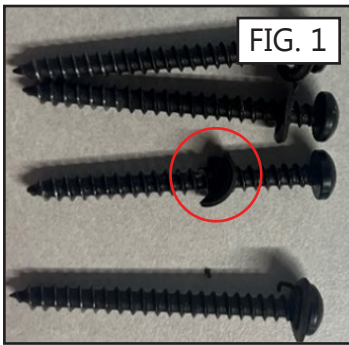

5. Remove 4 black snaps from the lens tub base.
  - 5.1. Use Allen Wrench or old top cover screw to pry back the snap so the edge of the flat square base is raised.  
NOTE: If you are using a screw only go a couple of revolutions down. If you go too deep, you will spread the legs of the snap and make it more difficult to remove (See FIG. 4).
  - 5.2. Use your flat head screwdriver to wedge in the opening you created in 5.1 and rotate side to side to remove the plastic snap (See FIG. 5). Repeat for all tubs.

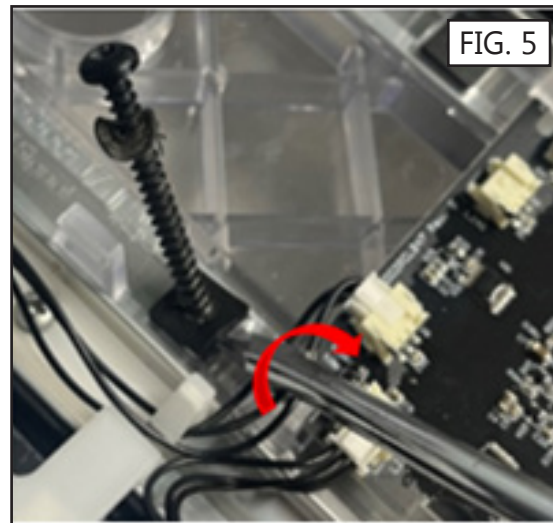
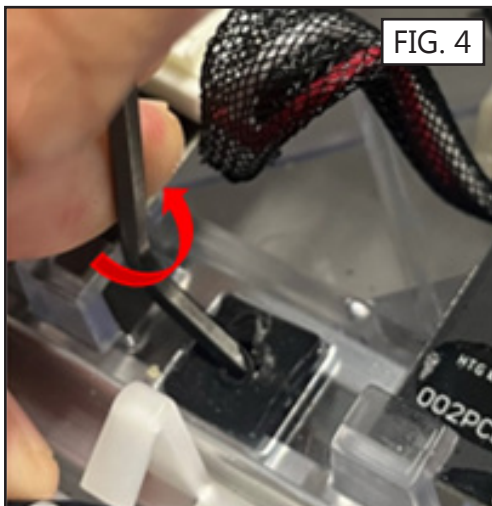

## TOP COVER REPLACEMENT INSTRUCTIONS (Cont.): //

6. Remove the corner reflector modules by unscrewing 2 – T15 screws on the end reflector to access hidden black snaps (See **FIG. 6**).

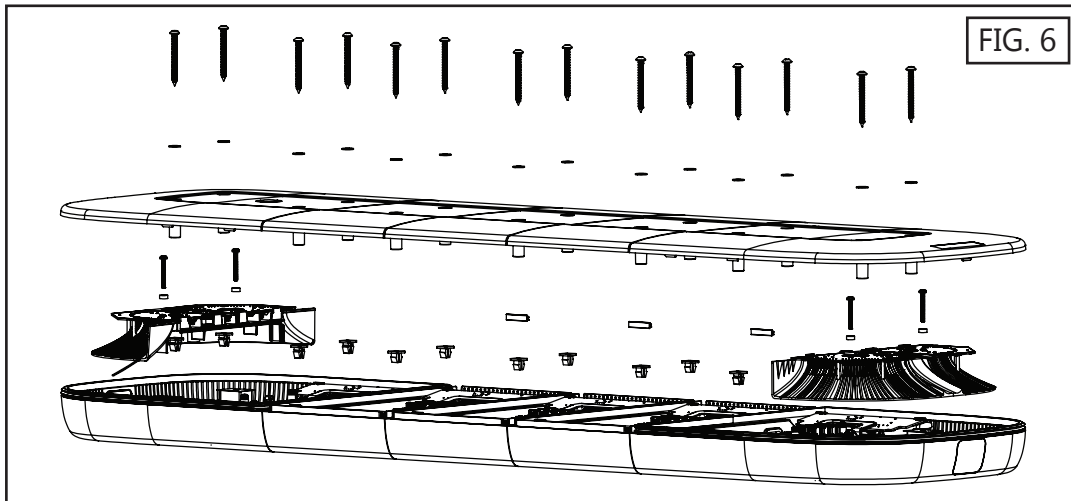

7. Replace plastic snaps. Make sure the orientation of the snap matches **FIG. 7** as you insert the new snap into the base tub. Install using the pad of your finger to press into place (See **FIG. 8**). If you need extra assistance to get snap to sit flush you can use the head of your screwdriver to install snap the remainder of the way (See **FIG. 9**). Repeat for all tubs.

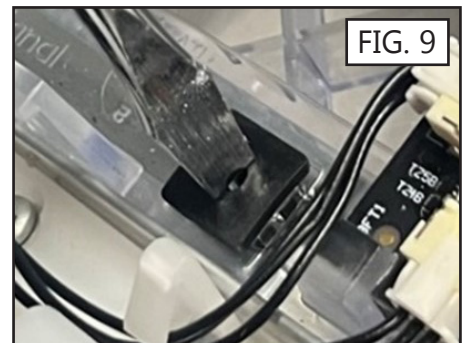
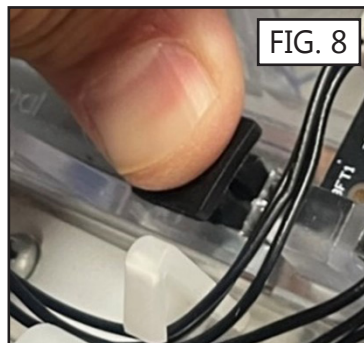
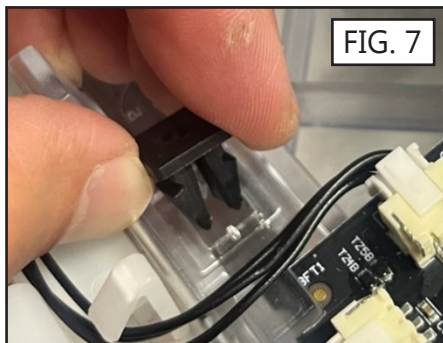

8. For the application of gasket, make sure the orientation of the gasket matches **FIG. 10** with the wipers of the gasket pointing down. Start the application of the gasket on the center middle of the tub. Work gasket around the 4 sides of the base tub. On the underside of the gasket pre spread the gasket legs apart to ease the application of the gasket to the base tub lens rib. Once you get back to the point you started applying the gasket use scissors to cut the excess gasket material away. Keep less than a 1/2" gap between the start and end pieces of the gasket for the best seal.
9. Using a soap water mixture with the ratio of 50:1 and a foam tip brush apply the gasket lubricant to exterior of portion of gasket.
10. Install new top cover to base lens. Squeeze the new top cover to the lens base using your palm on the top cover and wrapping your fingers around the base of the lens tub. Repeat for all top covers.
11. Place all replacement screw gaskets and screws back into top cover holes. Using your T20 Screwdriver tighten the screws until the base of the screw head is flush with the top of the gasket and the gasket stops spinning (See **FIG. 11**). Then tighten the screw another 1/8 of a revolution. This will get an equivalent torque of 9 in-lbs. NOTE: Do not overtighten screws.

